

GliderCG Scale

Digital CoG Balancer
Landing Gear Special Version

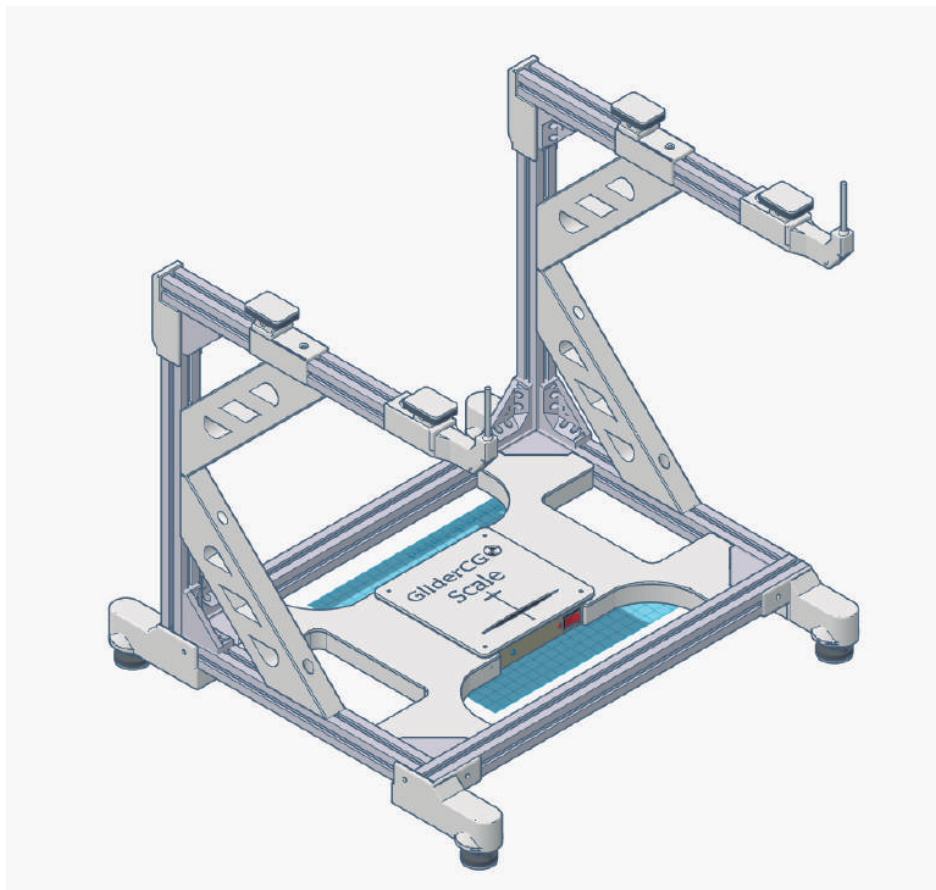

Eng Manual

Model 300-2019

Introduction

Dear customer, thank you very much for purchasing GliderCG Scale, a wonderful tool that will make the configuration of your aircraft models much easier and repeatable for long and pleasant flight seasons.

Unlike the existing center of gravity balances based on the balancing of the model on a supporting point, GliderCG uses the barycenter formula of a hyperstatic surface with 4 weight sensors to obtain the precise calculation of our CG without the need for balancing our models with the risks to the Integrity of them.

GliderCG Scale is a totally new concept of digital CoG balance for models up to 40Kg.

GliderCG Scale can be used with both large models and small models (from 200g) thanks to its novel design that allows the movement of the rear support points to adapt different wing sizes regardless of the fuselage width.

GliderCG Scale is able to provide accurate information about:

- CoG in our model.
- Model's total weight.
- Differential weight between both wings.

In addition, GliderCG Scale allows you to store the information of the CoG of your models and retrieve it to verify any change that may have occurred or use it as a target to calibrate your model again.

GliderCG Scale is a totally wireless (WiFi) device that uses a LiPo battery as a power source that must be recharged to work.

The data can be read in the web browser of any type of device, PC, MAC, Tablet PC or Smartphone without the need to install any application.

GliderCG Scale structure is formed by a reinforced aluminum frame that provides great rigidity and strength with a low weight.

The rest of the mechanical elements have been manufactured using the 3D FDM printing process in PLA (Polylactic Acid), an environment friendly material.

Concept

The condition for Static Equilibrium of the model plane, that is, it is not rotating, imposes the model weight is splitted in two reaction forces p_1 and p_2 applied in the supports A and B respectively, such as their resultant force passes thru the Center of Gravity of the model.

The position of the CoG is calculated by solving the equations:

$$a \times p_1 = b \times p_2$$

$$a + b = K \text{ constant}$$

K is known for the manufacture of the scale.

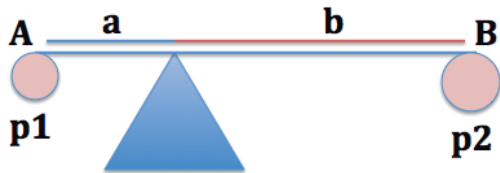

Characteristics

GliderCG Scale is a precision equipment that has been carefully manufactured, assembled and calibrated before it reaches your hands.

Material: Reinforced aluminum and plastic parts in PLA (Polylactic Acid)

Dimensions Height x Width x Depth: 400x410x370 mm.

Maximum fuselage width: 310mm

Maximum wing chord : 400mm approx

Wing support point distance: Between 100mm to 290mm

Power: 800mAh. Lithium rechargeable battery.

Charging : Micro USB Cable (not included)

Charging Time: About 1 Hour

Maximum recommended weight: 30Kg.

Minimum weight: 200g

Maximum fuselage size: 360mm width x 350mm high

Characteristics

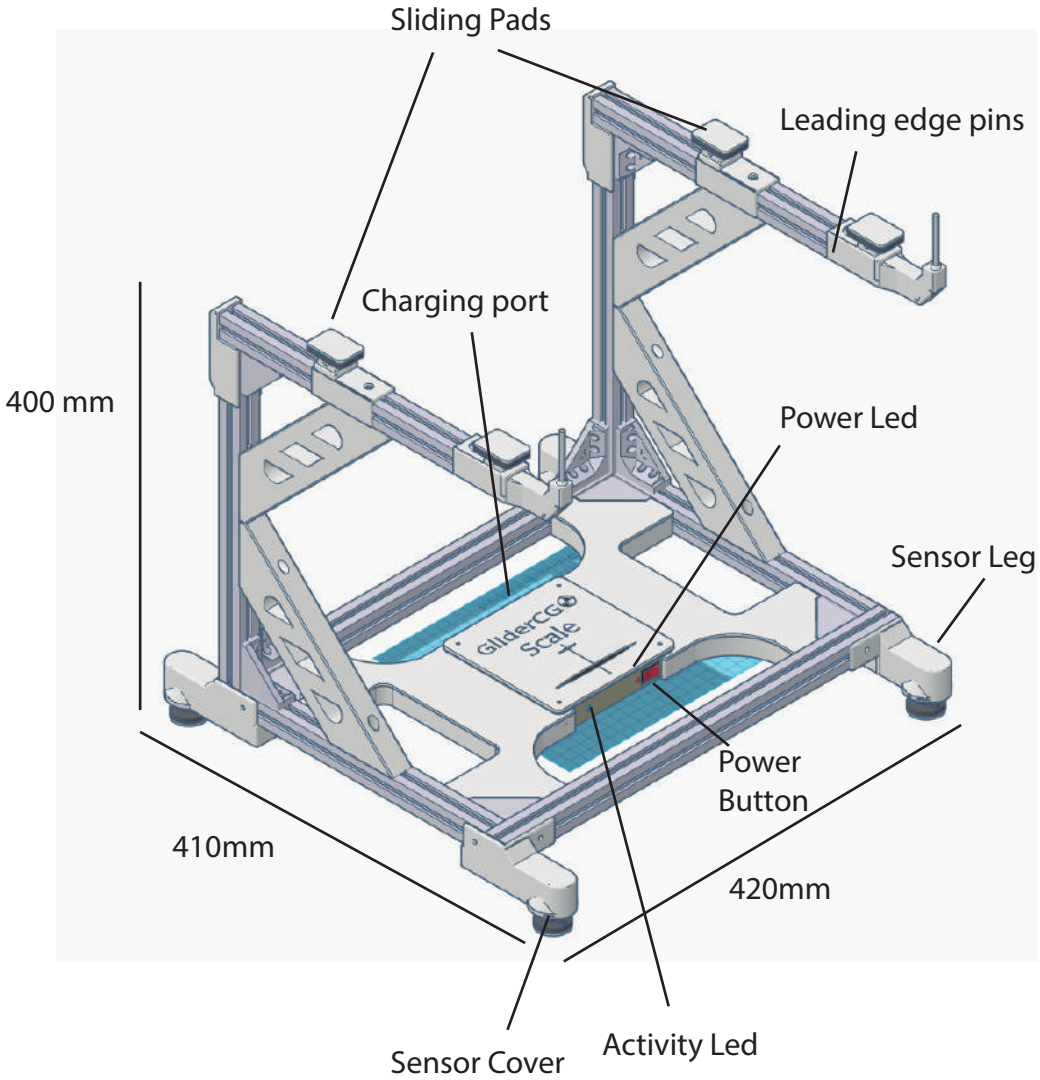

How to use

How to use GliderCG Scale

Power On the system

Make sure that the GliderCG Scale battery is fully charged, GliderCG Scale is a totally wireless device that uses a LiPo battery as a power source that must be recharged in order for it to work.

Before starting remove the protectors that cover the legs of the device and protect the sensors from impacts.

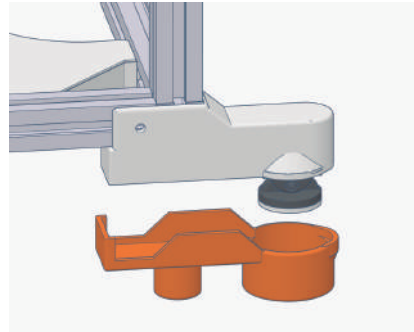
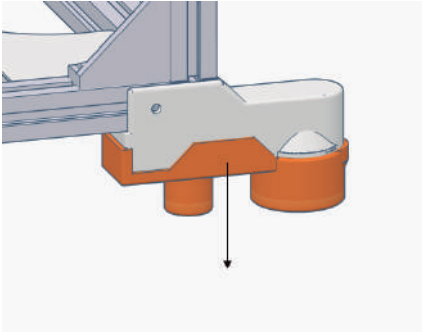

Place the pins that serve as a stop to the leading edge of the wing in its position

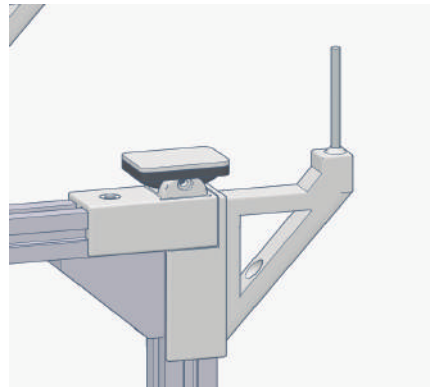
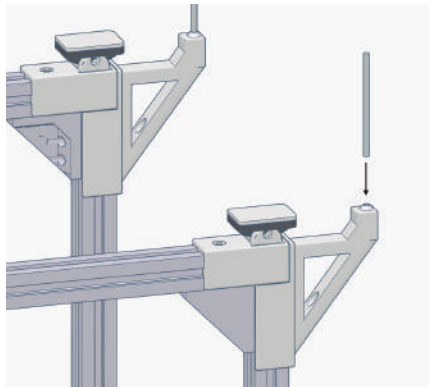

How to use

GliderCG Scale allows you to move the back supports to adapt different wing sizes, which will allow you to use your device with almost all models of your hangar from 200g.

To move the rear supports only loosen the fixing screws and move the supports to the desired point, repeating the process on both supports. Make sure that the distance between both supports and the front pin is the same.

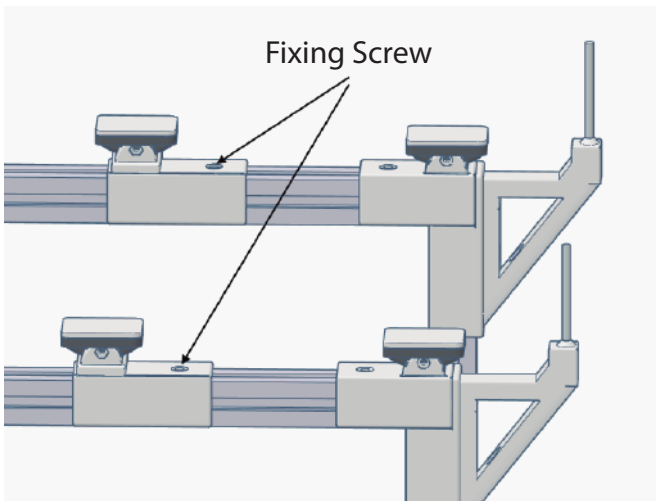

If, during the use of the GliderCG Scale, you wish to vary the distance of the supports to change between different models, once the distance has been modified you must perform a tare of the device as explained below.

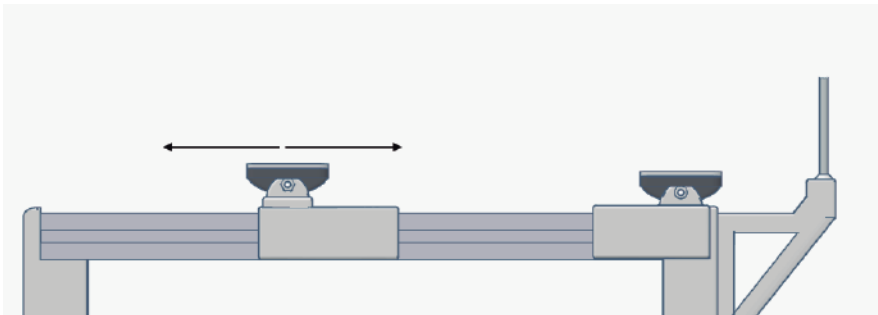

How to use

Once the protectors are removed, the front pins are placed and the rear supports are moved to the desired position, place the device on a smooth and level surface. The device measurement precision will depend to a great extent on whether it is correctly leveled and that its legs rest evenly on the surface.

Verify that there is no object on the device.

Turn on the device using the power button located on the right front. A red light will light indicating that it is operational and in a few seconds a blue light will also be lit on the same front indicating the start of system activity.

Connect the display to the system

In your Smartphone/PC, search for a WiFi AP called "GliderCG Scale" Connect to "GliderCG Scale" AP WiFi using 123456789 as password.

In many SmartPhones you will be advised that the network selected have no internetconnection and ask about selecting another WiFi conection. You might select "No".

The time while using GliderCG Scale your device will have NO internet connection.

Open your web browser and open a new window or browse to any new URL you never typed before like www.qkx.com You will get automatically redirected to GliderCG Scale screen.

If not succesfull to see GliderCG Scale screen then try <http://192.168.4.1> and you will get automatically redirected to GliderCG Scale screen.

How to use

Browse GliderCG Scale

Now you will be in the main screen that shows the center of gravity, in millimeters, as well as the total weight of the model in grams, **CG View**.

In the upper part, you can see a numbered rule that serves as a visual indicator of the CoG position.

At this time you can proceed to place your model on the upper pads of the GliderCG Scale, making sure that the leading edge of the wing contact the two front pins.

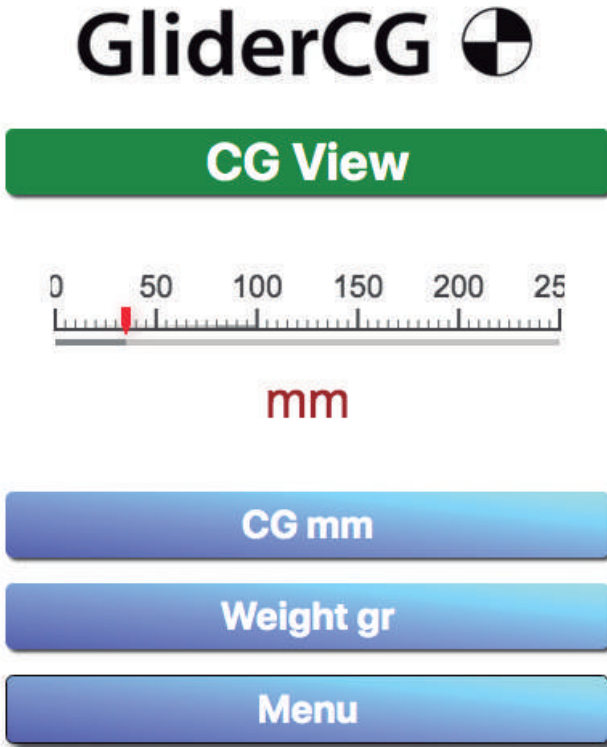

In the lower screen you can see a button to access the device menu.

How to use

Browse GliderCG Scale

By clicking on the Menu button you can access the different options of the device:

GliderCG

Menu

Scale Tare

CG View

Lateral Balance

Target View

Target config

The first menu option “**Scale Tare**” allows you to zero the weight measurement or tare the scale.

Because the back supports of the wing can be moved to fit the different wing sizes of your models, it is essential to make a tare each time you change the position of those supports.

How to use

Browse GliderCG Scale

Scale Tare

By clicking on the "Tare" button, the device will perform a Zero of all the sensors and will return you to the CG View main page.

GliderCG

Scale Tare

**Verify Scale is free
from any load
then press "Tare"**

Tare!

Menu

By clicking on the "**Menu**" option, we will return to the options menu.

The next menu option is **CG View**. By clicking on this button we will return to the CG View main screen where you can see the weight and center of gravity of our model.

The next option on the menu is "Lateral Balance".

How to use

Browse GliderCG Scale

Lateral Balance offers information on the weight of each side of our model as well as the weight difference in grams between both.

This is an especially useful option to check the deviation in weight between both surfaces and to correct it if necessary.

Using the aeronautical terms Port and Starboard that unequivocally identify each side of an aircraft and its corresponding color code, we can visualize the weight of each side of our model expressed in grams.

GliderCG

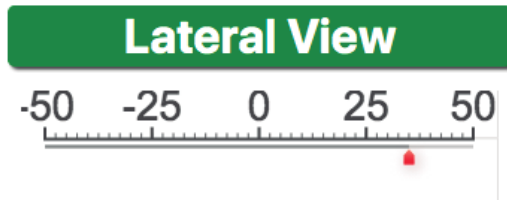

Port Weight

Strb Weight

Differential

diff

Menu

The numbered rule in the upper part will help us to identify in a simple way the weight deviation between both sides

How to use

Browse GliderCG Scale

Target View, allows us to visualize the settings of the position of the center of gravity that we have saved in the Target Select menu option that we will see later.

In this screen we can see how much our CoG position has changed since we saved until the present time, due to the different modifications that we make in our models over time and modify it if necessary or in case of having several equal models, adjust them in the same way.

GliderCG

Target View



ref Target mm

Target

CG_mm

weightTot_gr

Menu

The numbered rule in the upper part will help us to visualize in a simple way the change in the position of the center of gravity between measurements.

How to use

Browse GliderCG Scale

Target Select, the menu next option , allows us to save the settings of the position of the CoG of your models to recover them later.

By clicking on the Sel. option you can choose between the models in the list and enter the name and CoG position in millimeters.

GliderCG

Target Select

No.	Name	Target	
0	Plane0	250	Sel.
1	Plane1	250	Sel.
2	Plane2	250	Sel
3	Plane3	250	Sel.
4	Plane4	250	Sel.
5	Plane5	250	Sel.

Menu

Once the data has been entered or a model selected, two buttons will be visible: "Select" and "Save and Select" or "Cancel". Pressing them will return to the Target View screen where we can see the selected measure.

Charging:

GliderCG Scale is powered by a LiPo battery that needs to be recharged from time to time. Use a standard microUSB cable to charge from a computer, your field charger if you have a USB port or your mobile phone's charger.

GliderCG Scale has a protection circuit that shuts down when the battery is almost completely discharged. However, charge the unit as soon as possible to preserve the battery life.

WARNING: GliderCG Scale is a wireless device, however it will not present any damage if it is used in the flight field, both for the user and for other modelers, but **CAN CAUSE INTERFERENCE** to a receiver that is close to the transmitter. In the same way, in the presence of several stations, the functionality may be lost because it is an ISM device.

Recommendations

It is not recommended to perform measurements in places where there are air currents because they introduce additional loads on the sensors that distort the measurements and condition the accuracy of the device.

Try to locate the device on a horizontal surface ensuring that the supports load uniformly on it.

Turn off the device after each use and place the leg guards to prevent damage to the sensors.

Keep away from heat sources. The plastic material of the device, Polylactic Acid (PLA) can get deformed at high temperatures or in direct sunlight for a long time so it is not advisable for example to leave it in the car on sunny and hot days.

Keep away from any contact with water.

Do not exceed the maximum weight.

Safety and Security

GliderCG Scale is not a Toy. For use only from 18 years and up.

Avoid heat exposure and continuous direct sunlight.

Avoid water contact.

Safety information for lithium batteries

You must never open the lithium batteries, throw them onto a fire or expose them to shock, as toxic fumes might leak out and there is a risk of explosion.

Never handle leaking cells with bare hands.

In the event of contamination of the eyes or hands, it is necessary to rinse with plenty of water. A doctor should be consulted in the event of irritation of the skin or eyes.

Only dispose of completely discharged cells or packed cells protected against polarity reversal in accordance with the local disposal regulations.

Do not expose the cells to direct sunlight or hot temperatures, as otherwise there is a risk of overheating.

Maintain a storage temperature of <math><30^{\circ}\text{C}</math>.

Disposal Used batteries:

Batteries must not be disposed of in the domestic waste. Every consumer is legally obligated to dispose of batteries properly at the designated collection points in stores where batteries are sold.



Appliance:

At the end of its service life, never dispose of the appliance in the domestic waste. Check with your local authority or your local waste disposal services for options regarding environmentally-friendly disposal.



**Konformitätserklärung
Declaration of Conformity
Déclaration de conformité
Dichiarazione di conformità
Declaración de conformidad**

Hersteller / Verantwortliche Person
Manufacturer / responsible person
Fabricant / Personne responsable
Fabbricante / Persona responsabile
Fabricante /Persona responsable

GliderCG / Marco A. Moreno

erklärt, dass das Produkt
declares that the product
déclare que le produit
dichiara, che il prodotto
declara que el product

GliderGC Scale

folgenden Normen entspricht:
complies following standards:
correspond aux suivantes norms:
corrisponde alle seguenti norme:
cumple las siguientes normas

2014/53/UE
2006/66/CE
2014/30/UE
2001/95/CE

EN 60950-1:2007
EN50385 : (2002-12)
EN 300 328 V1.7.1: (2017)
EN 301 489-1 V1.8.1: (2008-04)
EN 301 489-17 V2.1.1 (2009-05)

Anschrift / Address / Adresse / Indirizzo / Dirección

Marco A. Moreno, Alonso Zamora Vicente, 5 28702 Madrid; +0034661808239

Email: GliderCG.info@gmail.com

Ort, Datum / Place and date of issue / Lieu et Date / Data e luogo /Fecha y lugar
Madrid, 28-Oct. 2018